

NOTES: DRAWING BASED ON OF SUPPLIED DRAWING10.01.2-ACC
 -ALL STEEL TO HAVE A GRADE OF ASTM-A36, CSA G40.21-44W OR BETTER OR LATEST EDITION.
 -ALL WELDING SHALL CONFORM TO CURRENT CSA W59 OR LATEST EDITION.
 -ALL WELDS TO BE CONTINUOUS.
 -ALL ROUGH, SHARP OR HAZARDOUS EDGES TO BE GROUND SMOOTH OR ROUNDED
 -SMALL CHANGES THAT DO NOT EFFECT LABOURT OR MATERIALS CAN BE MADE PRIOR TO MFG

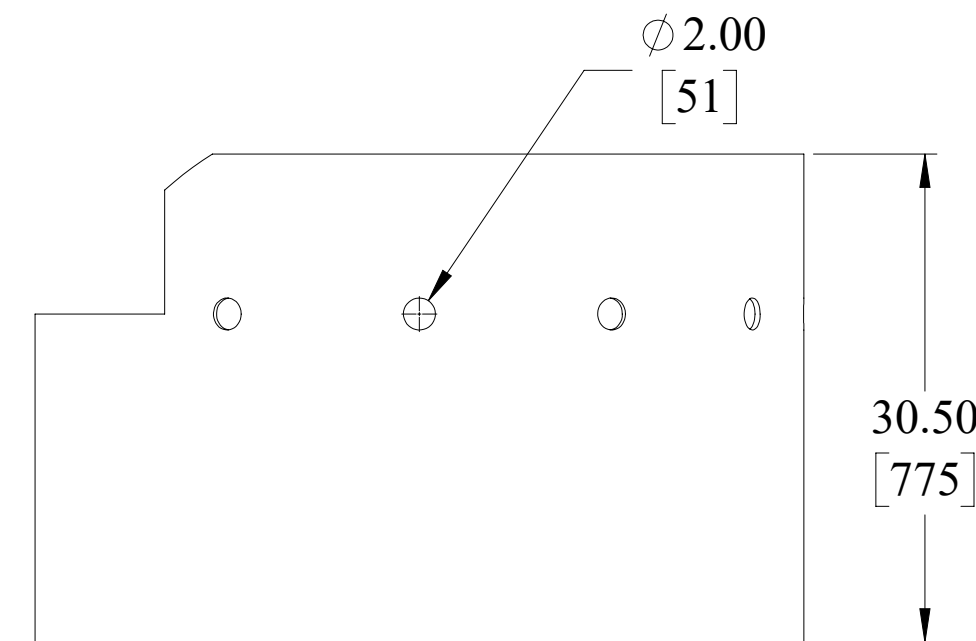

The information included in this document is proprietary and shall not be reproduced, transferred, or disclosed to others, for any purpose whatsoever, without the written authorization of Quantum Design and Technologies Inc.

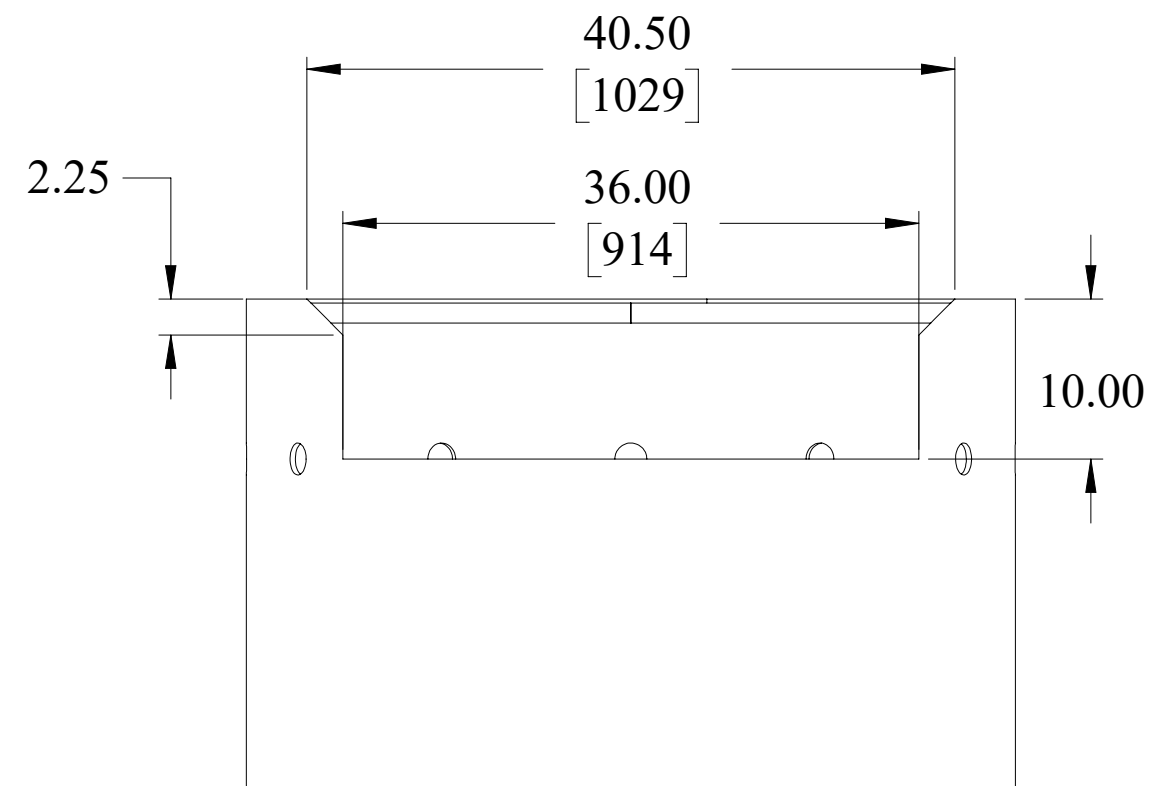
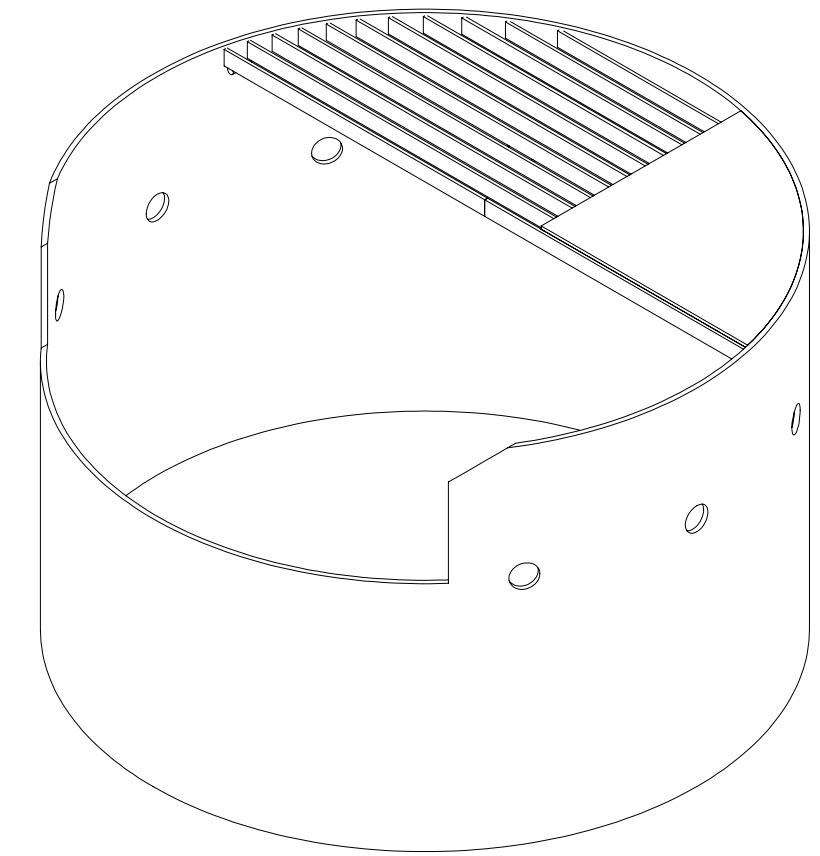
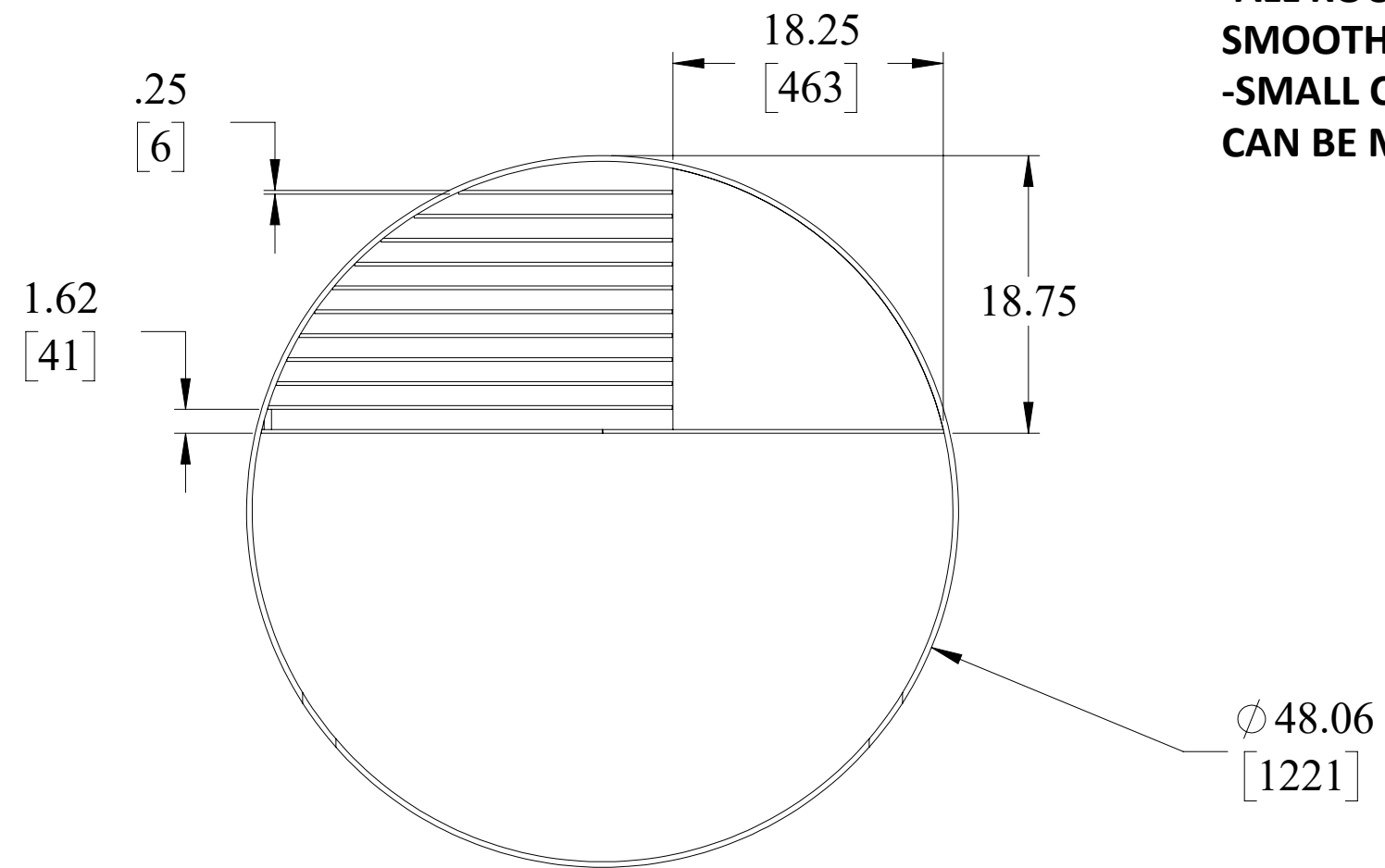
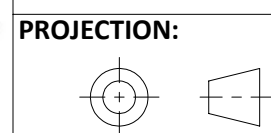

SHEET SIZE:
C

DRAWN:	NJB	PROJECT NAME:	AB 48IN DIA FIRE PIT		WT:	480.3lbs
CHECKED:	MSG	PROJECT #:			FINISH:	AS SUPPLIED MATERIAL
APP:	NJB	TITLE:	ASSEMBLY DRAWING			
DATE:	2020-11-19	SHEET 1 OF 1	DWG #:			REV: 0
			ABFP20-101			